

# AT1121, AT1123 X-ray and gamma radiation dosimeters

**Photon radiation  
energy range  
15 keV ... 10 MeV**

Portable multifunctional wide-range instruments for X-ray and gamma radiation dosimetry of the following types:

- Continuous long-term radiation
- Continuous short-term radiation
- Pulse radiation [AT1123]

## Operating principle

Main function of the dosimeter is the measurement of X-ray and gamma radiation within wide ranges of ambient dose equivalent rate and energy. Additional functions: detecting soft and hard gamma and beta radiation sources, measuring pulse and short-term radiation with exposure time assessment, and detecting moving sources as well.

Dosimeters automatically save maximum dose rate value for the time of operation and are able to store up to 999 measurement results in non-volatile memory for a long time and to subsequently transfer this data to PC.

Continuous performance self-testing is done during operation.

Remote control and external alarm unit can be attached to dosimeters for remote monitoring applications.



*Dosimeter with remote control and external alarm unit*



## Applications

- X-ray diagnostics
- Nuclear medicine
- Radiology
- X-ray and gamma-ray flaw detection
- X-ray and gamma-ray testing
- Search X-ray and accelerating apparatus
- Radiation accidents
- Radiation monitoring
- Nuclear industry
- Accelerating installations
- Research activities

## Features

- Tissue-equivalent detector - scintillation plastic
- High sensitivity results in rapid measurements with good statistical confidence
- Wide measurement range with 8 orders of magnitude and more
- Wide energy range starting from 15 keV
- Measurement of short-term exposure dose rate and time (from 0.03 s) for continuous radiation
- Measurement of average dose rate of pulse radiation with duration from 10 ns [AT1123]
- Large dedicated digital/analogue LCD screen with backlighting
- Integrated system for LED measurement path stabilization
- Sound and visual alarm in case threshold level is exceeded
- Remote control is available for remote measurement
- Fixed installation option with external audio-visual alarm with four groups of potential-free contacts for actuator control
- Connection to PC is available in order to create a continuous monitoring system with documenting function
- Tree types of power sources
- Severe operating conditions

Radiation type	AT1121		AT1123	
	H*(10)	H*(10)	H*(10)	H*(10)
X-ray	+	+	+	+
Gamma	+	+	+	+
Bremsstrahlung	+	+	+	+
Continuous long-term	+	+	+	+
Continuous short-term	+	+	+	+
Pulsed	-	-	+	+
Beta (detection)	+	+	+	+



**ATOMTEX**<sup>®</sup>

INSTRUMENTS AND TECHNOLOGIES FOR NUCLEAR  
MEASUREMENTS AND RADIATION MONITORING

# AT1121, AT1123

## X-ray and gamma radiation dosimeters

### Specification

<b>Detector</b>	Scintillation plastic, Ø30x15 mm
<b>Ambient dose equivalent rate measurement range</b>	
<i>Continuous long-term radiation</i> AT1121, AT1123	50 nSv/h ... 10 Sv/h
<i>Continuous short-term radiation</i> AT1121, AT1123	5 µSv/h ... 10 Sv/h
<i>Pulse radiation</i> AT1123	0.1 µSv/h ... 10 Sv/h
<b>Ambient dose equivalent measurement range</b>	10 nSv ... 10 Sv
<b>Energy range</b>	
<i>Continuous long-term and short-term radiation</i>	15 keV ... 10 MeV
<i>Pulse radiation (AT1123)</i>	15 keV ... 10 MeV
<b>Energy dependence relative to 662 keV (<sup>137</sup>Cs)</b>	
15 ... 60 keV (with protection cap "0.025 – 3 MeV")	±35%
60 keV ... 3 MeV (with protection cap "0.025 – 3 MeV")	±25%
60 keV ... 10 MeV (with protection cap "0.06 – 10 MeV")	±25%
10 ... 20 MeV * (with protection cap "0.06 – 10 MeV")	-50% max.
<b>Minimum duration of pulse radiation for pulse dose rate up to 1.3 Sv/s (AT1123)</b>	10 ns
<b>Minimum duration of continuous short-term radiation</b>	0.03 s
<b>Intrinsic relative measurement error</b>	
<i>Continuous long-term and short-term radiation</i>	±15% max.
<i>Pulse radiation (AT1123)</i>	±30% max.
<b>Sensitivity to <sup>137</sup>Cs gamma radiation</b>	70 cps/µSv·h <sup>-1</sup>
<b>Response time for dose rate change from 0.1 to 1 µSv/h (accuracy error ±10%)</b>	<2 s
<b>Time of <sup>137</sup>Cs gamma radiation dose rate measurement with statistical error ±15% (P=0.95) for the following dose rate:</b>	
50 nSv/h	≤60 s
0.3 µSv/h	≤10 s
over 2 µSv/h (Up to 10 Sv/h)	≤2 s
<b>Sensitivity to associated beta radiation of <sup>90</sup>Sr + <sup>90</sup>Y with filter (with protection cap "0.06 – 10 MeV") at 5 cm distance</b>	3 · 10 <sup>-7</sup> µSv·h <sup>-1</sup> ·Bq <sup>-1</sup>
<b>Burn-up life</b>	≥100 Sv
<b>Operation mode setup time</b>	1 min
<b>Power supply and continuous run time</b>	
Alternate or direct current mains	≥24 h
Built-in rechargeable Ni-MN battery	
AT1121	≥24 h
AT1123	≥12 h
<b>Protection class</b>	IP54

Design and specifications are subject to change without notice

**Working temperature range** -30°C ... +50°C

**Relative humidity with air temperature ≤35°C without condensation** ≤95%

**Overall dimensions** 233x85x67 mm

**Weight** 0.9 kg

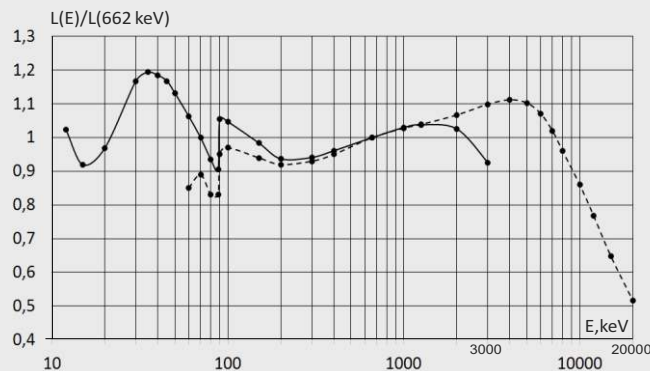

Normal energy dependence relative to 662 keV (<sup>137</sup>Cs)

(\*Energy dependence in 10 ... 20 MeV range is based on Monte Carlo method and is for reference only)

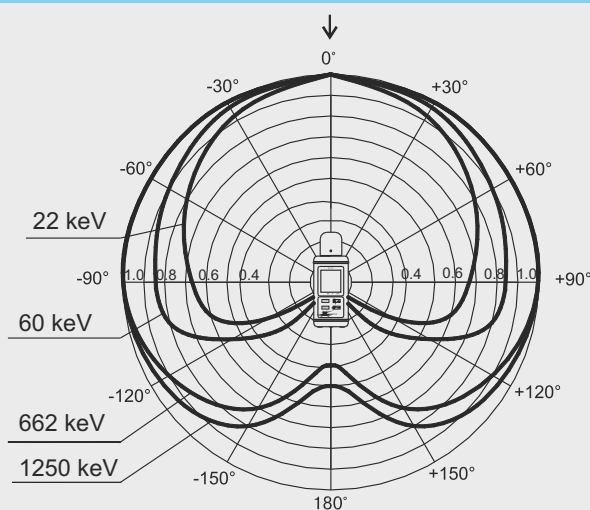

Normal dosimeter anisotropy for horizontal plane

The X-ray and gamma radiation dosimeters meet Safety standard requirements: IEC 61010-1:1990  
EMC requirements: EN 55011:2009,  
IEC 61000-4-2:2008, IEC 61000-4-3:2008,  
IEC 61000-4-4:2004, IEC 61000-4-5:2005,  
IEC 61000-4-6:2008, IEC 61000-4-11:2004

The X-ray and gamma radiation dosimeters have the pattern approval certificates of Republic of Belarus, Russian Federation, Kazakhstan, Ukraine, Lithuania, Uzbekistan, Azerbaijan



**ATOMTEX**®

<http://www.atomtex.com>

5, Gikalo st., 220005 Minsk,  
Republic of Belarus  
Tel./fax: +375 17 2928142  
E-mail: info@atomtex.com



Corporate Member  
of European  
Nuclear  
Society